



UTX-M06

High Sound Quality DSP Media Player



24bit
D/A CONVERTER



3WAY X-OVER



Bluetooth®

For iPhone users, please search "UTX-M06 Tuning APP" in APP Store to download and install it; for Android users, please scan the QR code on the right to download and install it directly.



Tuning APP

Table of Contents

Operating Instructions

Type of precautions 1

Copyright notice

Copyright notice 1

About the use of USB storage

Use of USB storage 2

Protected USB connector..... 2

Repair tools

Tools that may be required (depending on the vehicle) 3

Accessory list

Accessory list..... 3

Device description

Diagram of controller 4

Diagram of host machine..... 5

Diagram of complex line connection..... 6

Diagram of steering wheel controller connection..... 7

About MP3/WMA/WAV/FLAC/APE

About MP3/WMA/WAV/FLAC/APE 8

Function setting of wire controller

Sound setting 10

General setting..... 12

Bluetooth setting..... 14

Description of APP

Description of mobile APP - Homepage 15

Description of mobile APP - Preset EQ. 16

Description of mobile APP - Music 17

Description of mobile APP - Delay 18

Description of mobile APP - Channel.... 19

Description of mobile APP - EQ..... 20

Description of mobile APP - Sound

Mixing..... 21

Description of mobile APP - Setting..... 22

Description of PC software

Interface of PC software 23

Description of PC software 24

Technical parameters

Specifications 25

Functional parameters 25

Performance parameters..... 26

Installation and other precautions

Operating instructions for installation.... 27

Precautions for installation..... 28

When a problem occurs..... 29

Radio law on Bluetooth..... 30





Information

Hazardous substances 31

Information of maintenance stations..... 31

Operating Instructions

Type of precautions

 Prohibition	Indicates a prohibited action (must not be performed).
 Prohibition	Indicates that disassembly is prohibited.
 Mandatory	Indicates a mandatory operation (must be performed).
 Warning	Indicates that it should draw your close attention.

Warning

In case of problems, please stop using the device immediately. 

Otherwise, it may result in personal injury or damaged product. Please return the product to the authorized Alpine dealer or nearby Alpine service center to repair.

The product is only suitable for 12V negative-grounded vehicles. 

Otherwise, it may lead to an accident like fire, etc.

Please call the professionals to wire and install. 

It needs professional expertise and experiences to wire and install the product. Please contact the dealer from whom you bought the product to install it for safety.

Please do not disassemble or refit. 



Otherwise, it may result in an accident, fire or electric shock.

Small items like bolts or screws should be kept out of the reach of child. 

If ingested, it may result in severe damage. Once ingested, please seek medical attention immediately.

Please do not use any function that may distract you during driving. 

Any function that may influence your attention should be used only when the vehicle is stopped completely. To use these functions, please first stop your vehicle in a safe area. Otherwise, it may result in an accident.

During driving, you must maintain the volume at a level such that the noise outside can still be heard. 

It is very dangerous not to clearly hear an emergency vehicle alarm and road warning signal (such as a railway crossing) and may result in an accident. Moreover, a too large volume may damage your hearing.

Caution

Product cleaning 

Please clean the product regularly with a soft dry cloth. For any dirt difficult to clean, only water can be used to soak the cloth. Any other solvents may lead to dissolution.

Temperature 

Before starting the device, please ensure that the temperature inside the vehicle is between +60 °C and -20°C.

Repair 

In case of problems, please do not repair them by yourself. Please return the product to the authorized Alpine dealer or nearby Alpine service center to repair.

Installation site 

The device cannot be installed at the following locations:

- Under direct sunlight and near a hot source.
- With high humidity and near a water source.
- Dusty sites.
- Environments with violent vibration.

Copyright notice

The text mark and logo of Bluetooth® are the registered trademarks that Bluetooth SIG, Inc. Alpine Electronics has been authorized to use these text marks and logos. Other trademarks and names all belong to their holders.

Products with a High-Resolution mark conform to the standards defined by the Acoustical Society of Japan. Alpine Electronics has been authorized by the Acoustical Society of Japan to use the High-Resolution mark.

* Electronic products should be discarded via an appropriate recycling channel to reduce electronic waste pollution.

Use of USB storage









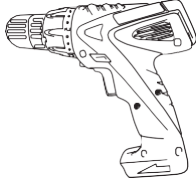
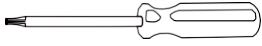

Under no circumstances shall Alpine be liable for any loss of data, even if those occur during the use of this product.

- To prevent failure or damage, please pay attention to the points below. Please read through the user manual of the USB storage.
 - Please don't touch the terminal with your hand or metal.
 - Please prevent the USB storage from violent vibration.
 - Please don't bend, drop, dismantle, or modify the device or immerse it in water.
- Avoid use or storage in the following places.
 - In a vehicle under direct sunlight or exposed to the sun at high temperature.
 - Places where high humidity or corrosive objects may be present.
- Install the USB storage in such a place that the operation by the driver would not be hindered.
- The USB storage may not operate correctly in places at excessively high or low temperatures.
- Only approved USB storage can be used. Please note that even an approved USB storage may be unable to operate correctly due to different types or states.
- Functions of the USB storage cannot be guaranteed. Please use the USB storage in accordance with the terms of the agreement.
- Depending on the type and state of the USB storage or settings of the encoding software, this device may not play or display normally.
- The device cannot play copy protected (copyright protected) files.
- It may take a while to start playing files in the USB storage. If there are special files other than audio files in the USB storage, it may take longer to play or search files.
- This device can play files with extensions of "mp3", "wma", "wav", "flac", and "ape".
- Please do not add the above extensions to non-audio data. Such non-audio data would be unrecognizable. Play of such non-audio data may damage the speaker or noise from the amplifier.
- It is recommended to back up important data on a PC.
- Never remove the USB device while it is playing. Switch the SOURCE to other options than USB before removing the USB device to prevent damage to the storage.

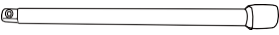
Protected USB connector

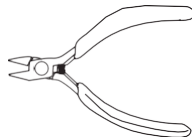
- The device provides a USB port on the front and a MICRO SD port on the rear and supports the connection and use of USB storage.
- Only USB storage can be connected to the USB ports of this device, and normal use of other USB products cannot be guaranteed when connected.
- If a USB connector is used, make sure you use the USB extension cable (accompanied with the product).
- Depending on the USB storage device connected, this device may be unable to operate or unable to execute some functions.
- This device supports FAT16/32 file system.
- Please make sure that the number of songs in the connected USB storage is no more than 5000 (maximum total number of playable songs). Otherwise, they cannot be played normally.
- This device can play audio files in the format of MP3/WMA/WAV/FLAC/APE.
- This device can display the performer's name/song title/song album etc. Some special characters may not be displayed correctly.

Tools that may be required (depending on the vehicle)

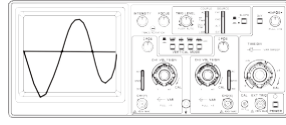
Panel removing tool 	Socket 	Electric drill 	Torx screwdriver 
Phillips screwdriver 	Sleeve wrench 	Wrench 	Wire cutter 
Wire crimper 	Wire stripper 	Spectrum analyzer 	Oscilloscope 

Accessory list





Power cord 	High level input line 	USB extension cable (1.5 m) 
Controller extension cable (2.5 m) 	Complex line 	Mounting bracket × 2 
Self-tapping screws (M4×20) 	Machine tooth screws (M5×8) 	

Diagram of controller

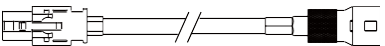
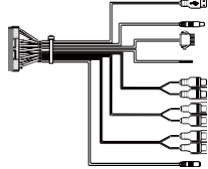
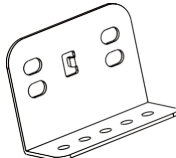

1	SRC ← → button	Short press the button to select the master audio source: USB, Bluetooth music, high level or AUX (USB by default); press and hold the button for more than 2 seconds to turn on/off the mixing mode.
2	⏮ button	USB: short press the button to select the previous track; press and hold the button for more than 2 seconds to fast backward. Bluetooth music: select the previous track.
3	▶/⏸/-↻ button	Short press the button to switch between Pause/Play: press and hold the button for more than 2 seconds to switch between Shuffle Play/Single Cycle.
4	⏭ button	USB: short press the button to select the next track; press and hold the button for more than 2 seconds to fast forward. Bluetooth music: select the next track.
5	↶ button	Go back to the previous level.
6	🔇/-⏻ button	Short press the button to mute the device; press and hold the button for more than 2 seconds to turn off the device. * The device can be turned on by pressing any button.
7	Rotating knob	Main interface: rotate the knob to the left or right to adjust the volume; short press the knob to enter the track list; press the knob for more than 2 seconds to enter the Setting interface. Setting interface or track list: short press the knob to confirm the selected item.
8	Remote control sensing window	A window for remote control sensing

Diagram of host machine

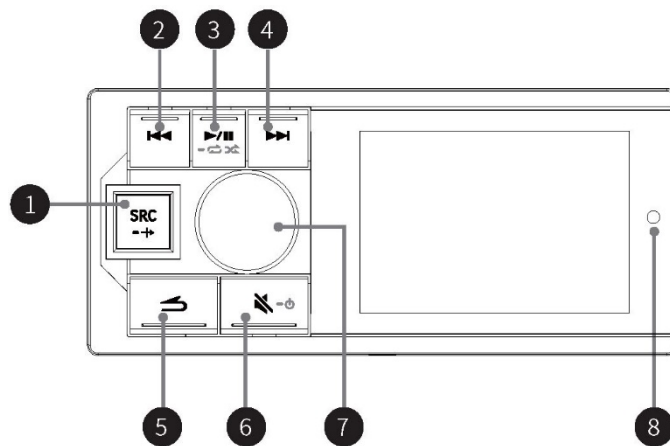
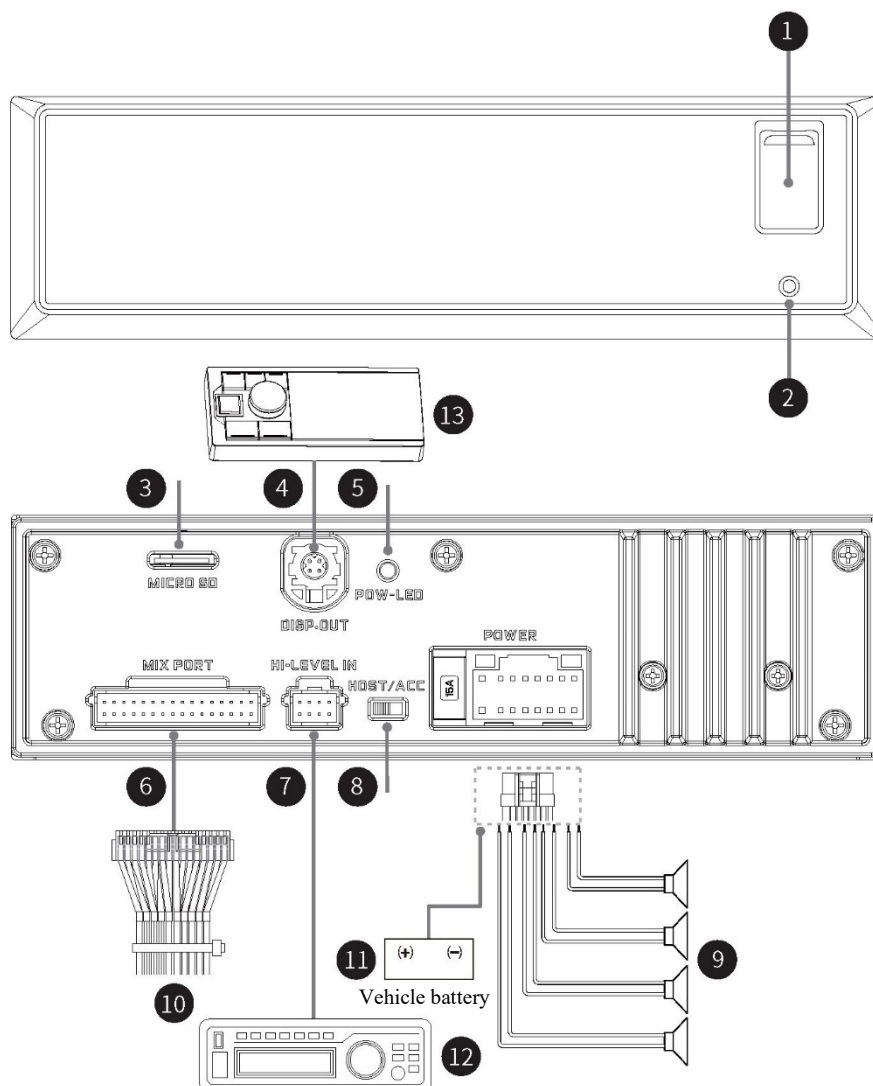

1	USB interface	Used to connect USB flash disk or USB HUB.
2	Reset button	Press and hold the button for 3 seconds to restart the host machine.
3	MICRO SD interface	Used to connect MICRO SD card.
4	Controller interface	It can be connected to the controller for tuning.
5	Power lamp interface	Power lamp.
6	Complex line interface	Complex connection mode integrated with 8 types of input and output interfaces
7	High level input interface	Connected to the power output of an on-vehicle CD/DVD player.
8	Input select switch interface	If the switch is put to "ACC", the device will be started by ACC; if put to "HOST", the device will be started by the high voltage level input signal H1-/H1+.
9	Power output interface	Connect the external power amplifier
10	Complex line	including 1 group of 3.5 mm socket audio input interface, 3 groups of RCA audio output interface, USB 2.0 interface, steering wheel controller interface, and Alpine system matching interface (for connection with DSP product).
11	Vehicle battery	Connect the vehicle battery.
12	On-vehicle CD/DVD player	Provide high level input signal.
13	Controller	By connecting the controller, play control, volume adjustment and audio source selection can be performed.

Diagram of complex line connection

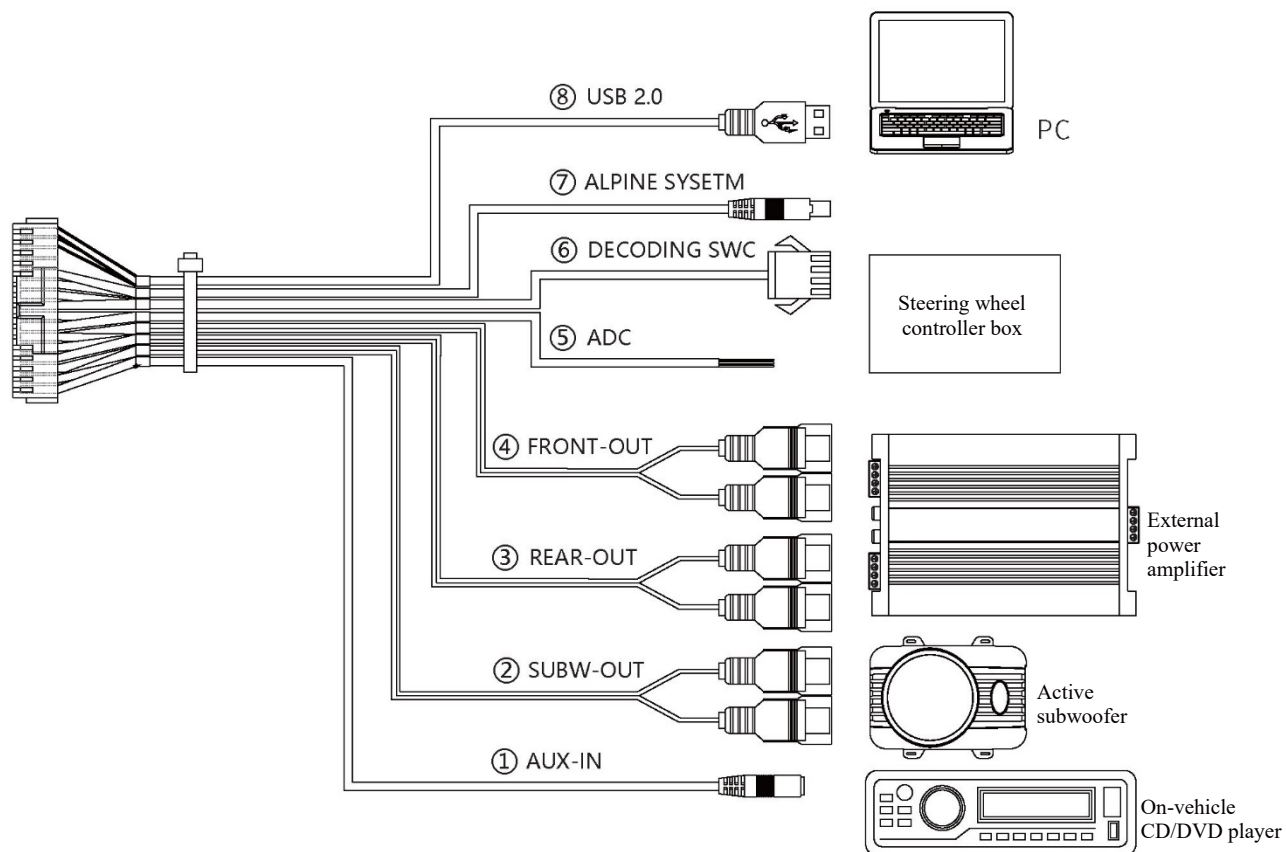

1	AUX-IN	Low level input, can be connected to an on-vehicle CD/DVD player.
2	SUBW-OUT	Subwoofer output, can be connected to an active subwoofer.
3	REAR-OUT	Rear sound field RCA output, can be connected to an external power amplifier.
4	FRONT-OUT	Front sound field RCA output, can be connected to an external power amplifier.
5	ADC	ADC steering wheel controller interface, supports resistive control of the steering wheel.
6	DECODING SWC	Decoding type steering wheel controller interface (not supported for now, will be updated in the near future).
7	ALPINE SYSTEM	It can be connected to Alpine on-vehicle DSP and only supports products with matching controller interfaces.
8	USB 2.0	USB 2.0 interface, can be connected to a PC for tuning operation.

Diagram of steering wheel controller connection

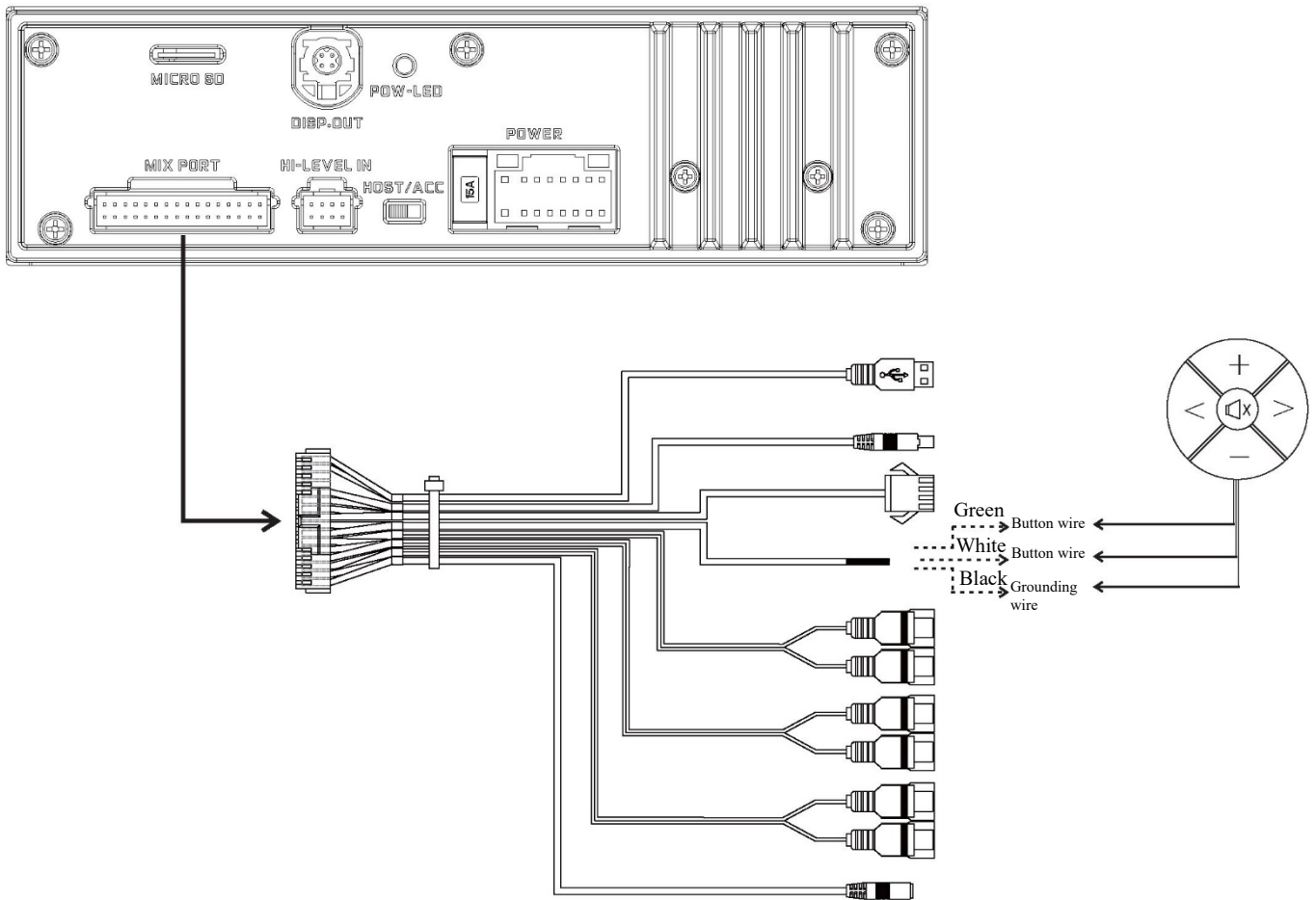

1	Type of steering wheel controller	Adjust the pull-up strength according to the various types of steering wheel controllers to adapt to the steering wheel controller of different vehicle models.
2	Play/Pause	Select "Play/Pause", short press it to complete learning.
3	Previous track	Select "Previous track", short press it to complete learning.
4	Next track	Select "Next track", short press it to complete learning.
5	Volume+	Select "Volume+", short press it to complete learning.
6	Volume-	Select "Volume-", short press it to complete learning.
7	Mute	Select "Mute", short press it to complete learning.
8	Audio source	Select "Audio source", short press it to complete learning.

**Connect the green and white wires with the button wires of the steering wheel and connect the black wire with the grounding wire. Please connect the wires based on the actual vehicle model. For details, please contact your Alpine dealer.*

About MP3/WMA/WAV/FLAC/APE

Except for personal use, it is strictly forbidden by copyright laws and international conventions to copy, distribute, or transmit any audio data (including MP3/WMA/WAV/FLAC/APE data), whether for free or for a charge, without the consent of the copyright owner.

1	MP3	MP3, with the formal name of “MPEG Audio Layer 3”, is a compression standard defined by MPEG, a joint executing agency under ISO (Organization for Standardization) and IEC. An MP3 file contains compressed audio data. MP3 encoding can compress audio data at an extremely high ratio, thus reducing the music file's size to one tenth of the original size. At the same time, the sound quality remains close to that of CD. MP3 achieves such a high compression rate by removing sounds that cannot be heard by humans or that are drowned by other sounds.
2	WMA	WMA, or “Windows Media™ Audio”, is compressed audio data. WMA is similar to MP3 audio data.
3	WAV	WAV is an audio file format developed by Microsoft. It conforms to the file specifications of RIFF (Resource Interchange File Format) and is used to save audio information and resources on the Windows platform. It is widely supported by the Windows platform and its applications. This format also supports several compression algorithms such as MSADPCM and CCITT A LAW, and supports multiple audio digital sampling frequencies and sound channels. A WAV file of standard format has the same 44.1 kHz sampling frequency and 16 digitalizing bits as CD format, and thus have nearly the same sound quality as CD! It is the audio format that is the closest to lossless music, and therefore the file size is large.
4	FLAC	FLAC can be explained as lossless audio compression and coding. FLAC is a well-known free audio compression and coding technology characterized by lossless compression. Different from lossy compression and coding such as MP3 and AAC, it will not destroy any original audio information.
5	APE	APE is one of the popular lossless compression formats for digital audio. Different from lossy compression formats such as MP3 that removes data (to which the human ear is not sensitive) irreversibly to reduce the size of the original file, lossless compression formats such as APE reduce the file size by a more refined recording method, so that the restored data is the same as the original file. The integrity of the file is ensured.

Create MP3/WMA/WAV/FLAC/APE files

Use software with MP3/WMA/WAV/FLAC/APE coding and decoding for compression of audio data. For details about the creating of MP3/WMA/WAV/FLAC/APE files, please refer to the user manual of the software. The MP3/WMA/WAV/FLAC/APE files that can be played by this device have the following extensions.

MP3: “mp3”

WMA: “wma”

WAV: “wav”

FLAC: “flac”

APE: “ape”

Supported play sampling frequency and bit rate:

1	MP3	Sampling frequency: 48kHz、44.1kHz、32kHz、24kHz、22.05kHz、16kHz、12kHz、11.025kHz、8kHz Bit rate: 8-320kbps
2	WMA	Sampling frequency: 48kHz、44.1kHz、32kHz、22.05kHz、16kHz、11.025kHz、8kHz Bit rate: 12-192 kbps (stereo) 0-128 kbps (mono channel)
3	WAV	Sampling frequency: 192kHz、176.4kHz、96kHz、88.2kHz、48kHz、44.1kHz、32kHz、24kHz、22.05kHz、16kHz Digitalizing bit: 8bit、16bit、24bit
4	FLAC	Sampling frequency: 192kHz、176.4kHz、96kHz、88.2kHz、48kHz、44.1kHz、32kHz、24kHz、22.05kHz、16kHz、12kHz、11.025kHz、8kHz Digitalizing bit: 8bit、16bit、24bit
5	APE	Sampling frequency: 192kHz、176.4kHz、96kHz、88.2kHz、48kHz、44.1kHz、32kHz、24kHz、22.05kHz、16kHz、12kHz、11.025kHz、8kHz Digitalizing bit: 16bit、24bit

Depending on the sampling frequency, this device may not play correctly.

When playing a VBR (variable bit rate) encoded file in the USB mode, the play time may not be displayed correctly.

Sound setting

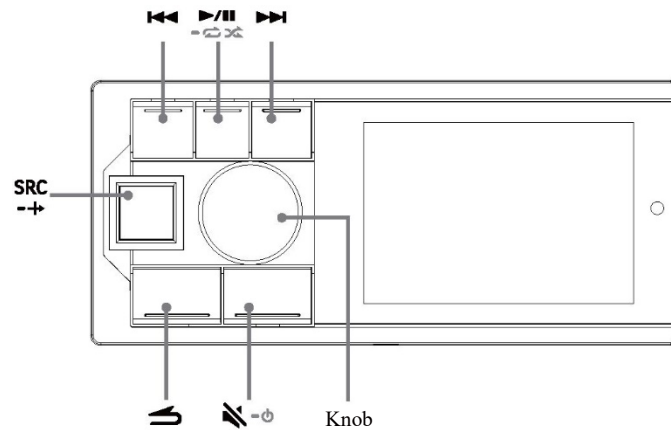

You can set this device flexibly based on your preference and purpose. You can change audio settings in the sound setting menu. Use steps 1 to 5 to choose any setting mode to change the setting.

1	Press and hold the knob for at least 2 seconds to enter the settings interface.
2	Turn the knob to select “Sound Effect Setting” and then short press the knob: Preset Equalizer ↔ Sound Effect Setting ↔ General ↔ Bluetooth
3	Turn the knob to select the “Sound Effect Setting” menu and then short press the knob: Treble*1 ↔ Bass*1 ↔ Mega Bass ↔ Channel Balance ↔ Fader*2 ↔ Parametric Equalizer ↔ Input Source Volume ↔ Time Correction ↔ Divider Settings*3 ↔ Sound Setting Storage ↔ Sound Effect Clear Setting*4 <i>*1 Any change made to the “Preset Equalizer” or “Parametric Equalizer” will be reflected in the settings of the other.</i> <i>*2 When the “Divider Settings” is set to “Active Divide by 3”, adjustment cannot be made.</i> <i>*3 Depending on the “Divider Settings”, the setting items may be different.</i> <i>*4 When “Sound Effect Clear Setting” is enabled, adjustments cannot be made to the preset sound effect.</i>
4	Turn the knob to change the setting or enter the next level, and then short press the knob.
5	Press SRC/--+ to deactivate setting mode. <i>Press ↩ to return to the previous sound menu mode.</i>

For a detailed description of the selected setting items, please refer to the applicable sections below.

1	Preset equalizer	A total of 10 typical equalizer settings will be preset in the factory for a variety of audio source materials. Standard (initial setting) ↔ Popular ↔ Rock ↔ News ↔ Jazz ↔ Electronic ↔ Hip-hop ↔ Light music ↔ Country ↔ Classic ↔ Custom <i>Caution: The "Custom" item will be displayed when an adjustment is made to the Bass/Treble or Parametric Equalizer settings, and the "Custom" item will be displayed.</i>
2	Treble/Bass level	You can select Treble or Bass and adjust the level based on your own preference. The adjustable range is: -7 ~ +7 (initial value: 0)
3	Bass setting	When the subwoofer is turned on, you can adjust the subwoofer's phase output level, phase setting and bass level.
4	Balance setting	Channel balance, adjustable range: L15~0~R15 (initial value: 0) Fader, adjustable range: F15~0~R15 (initial value: 0)
5	Parametric Equalizer	You can modify the equalizer settings to better fit the response curve to your preference, including 10 sections of EQ adjustable frequency range, Q value and gain.
6	Input source volume	Select input source volume adjustment in the sound effect setting mode. The adjustable range is: -60dB~0dB (initial value: 0dB)
7	Time correction	Select "Adjust time correction" in the sound effect setting mode, and turn the knob to select the speaker or time correction unit for adjustment.
8	Frequency divider setting	In the Setting interface, press and hold ►►, ►/■, and ◀◀ for more than 2 seconds each in sequence, turn the knob to select "Divide-by-3" or "Divide-by-2" mode, and press ►/■ to confirm the selection of divider system.
9	Sound storage setting	Dealer setting: can be called by short pressing the knob; in the setting interface, press and hold ►►, knob, and ◀◀ for more than 2 seconds each in sequence <i>to call the electrical test mode so that the storage can be used</i> ; Custom setting: short press the knob to use the custom setting; press and hold the knob for more than 2 seconds to store the tuned sound parameters.
10	Sound effect clear setting	When this setting is enabled, the settings on sound effects such as preset equalizer will become invalid. Disable this setting and the previous sound effect settings will be restored.

General setting

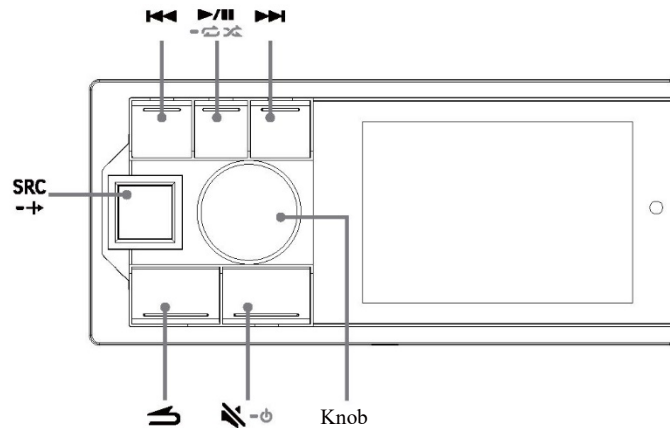

You can set this device flexibly based on your preference and purpose. In the general setting menu, you can change the general settings, display settings and so on. Use steps 1 to 6 to choose any setting mode to change the setting.

1	Press and hold the knob for at least 2 seconds to enter the settings interface.
2	Turn the knob to select the desired item and then press the knob: Preset Equalizer ↔ Sound Effect Setting ↔ General ↔ Bluetooth
3	Turn the knob to select General, and then press the knob: Auxiliary audio source ↔ Built-in power amplifier ↔ Steering wheel controller learning ↔ Alpine system matching ↔ Dimmer control ↔ Language setting ↔ Restore factory settings ↔ About
4	In the setting interface, press and hold ►►, knob, and ►► for more than 2 seconds each in sequence to call the electrical test mode: Firmware update ↔ Dealer setting ↔ Serial number
5	Turn the knob to change the setting and then press the knob.
6	Press SRC/→ to deactivate setting mode. <i>Caution: Press ◀ to return to the previous sound menu mode.</i>

For a detailed description of the selected setting items, please refer to the applicable sections below.

1	Auxiliary audio source	Auxiliary audio source options: Bluetooth ↔ High level ↔ AUX ↔ Off Primary source attenuation: it is used to set the amount of attenuation needed for the primary source when mixed sources are input, and the adjustable range is 0~100%.
2	Built-in power amplifier	When connected to an external amplifier, sound quality can be improved by stopping the power supply to the built-in amplifier. <i>Caution: When the "built-in amplifier" is set to "Off", the system will not output any sound.</i>
3	Steering wheel controller learning	Wire the steering wheel controller depending on the actual vehicle model. After connecting the host machine, allow the device to learn the steering wheel through the controller. Short press "Play/Pause", "Previous", "Next", "Volume +", "Volume -", "Mute" and "Audio source" and wait for the buttons on the steering wheel to be pressed down to finish the learning and achieve control of the steering wheel with the controller.
4	Alpine system matching	It can be connected to Alpine on-vehicle DSP and only supports products with matching controller interfaces. <i>For details, please contact your Alpine dealer.</i>
5	Dimmer control	Dimmer control: when dimmer control is set to "Manual", the light level can be adjusted; when dimmer control is set to "Auto", the illuminating brightness of the host controller will be reduced when the headlights of the vehicle are ON. Black screen setting: the screen will turn off after 30 seconds of no operation. Press any button and the screen will turn on.
6	Language setting	You can choose the interface display in Chinese or English based on your personal preference.
7	Restore factory settings	After restoring factory settings, except for the tuned "Dealer Settings", all setting items will be restored to the factory default value.
8	About	Select the About interface and you can check information about the device, such as Software version/Device version/Device name.

Bluetooth function

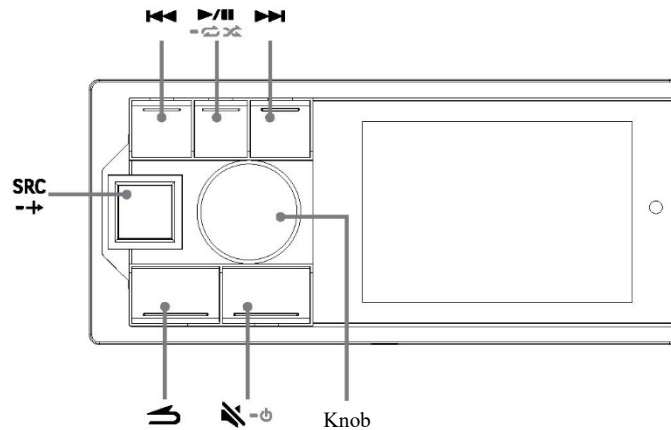

Bluetooth is a wireless technology used for short distance communication between mobile devices and PCs. It can realize data transmission between Bluetooth-compatible devices. If the distance between two devices is less than 10 meters, they can transmit data with Bluetooth within the approved 2.4 GHz frequency spectrum.

1	Connect via Bluetooth	<p>When the host machine is powered on for the first time and is not connected to any device via Bluetooth, you need to wait for the mobile phone to pair and connect it. Search “UTX-M06-XXXXXX” directly on the mobile phone background and connect to it. “” is a 6-digit random code, for example: UTX-M06-A00414. For detailed operation, please refer to the below:</p> <ol style="list-style-type: none"> 1. Enable Bluetooth on the mobile phone; 2. Search pairable devices on the mobile phone background, and select “UTX-M06-XXXXXX” to pair. 3. After pairing successfully, press and hold the knob for a while to enter the Setting interface → General → Bluetooth, press “Bluetooth” to enter the interface, which shows “Connected”. 4. If you need to disconnect the Bluetooth device, short press the knob and it will prompt the user to “Confirm to disconnect the Bluetooth device”. Short press it again to confirm disconnection. After disconnection, it will show “Disconnected”. After disconnection, if you need to connect the Bluetooth again, perform step 2. <p><i>Caution: This device can only pair with one Bluetooth compatible device at a time and cannot be connected to two Bluetooth compatible devices at the same time.</i></p>
2	Bluetooth music	<ol style="list-style-type: none"> 1. Press SRC/-+ to choose Bluetooth music. 2. Press ◀◀ to select the previous track. 3. Press ▶▶ to select the next track. 4. Press ▶/ /-◀ to switch between pause and play. <p><i>Caution: 1. This operation varies depending on the device connected. 2. This device has separate memory for volume settings of Bluetooth audio sources.</i></p>
3	About Bluetooth	<p><i>Depending on the Bluetooth version, Bluetooth compatible devices may be unable to communicate with this device.</i></p> <ol style="list-style-type: none"> 1. It is not guaranteed that this device can be used normally in conjunction with all Bluetooth compatible devices. For the operation of Bluetooth compatible devices, please consult your Alpine dealer or visit Alpine’s website. 2. Depending on the environment, Bluetooth wireless connection may be unstable. 3. Depending on the Bluetooth compatible device connected, this function may vary. Please also refer to the user manual of the device connected. 4. When searching for this device on the mobile phone, the name of this device is “UTX-M06-XXXXXX”.

Description of mobile APP - Homepage

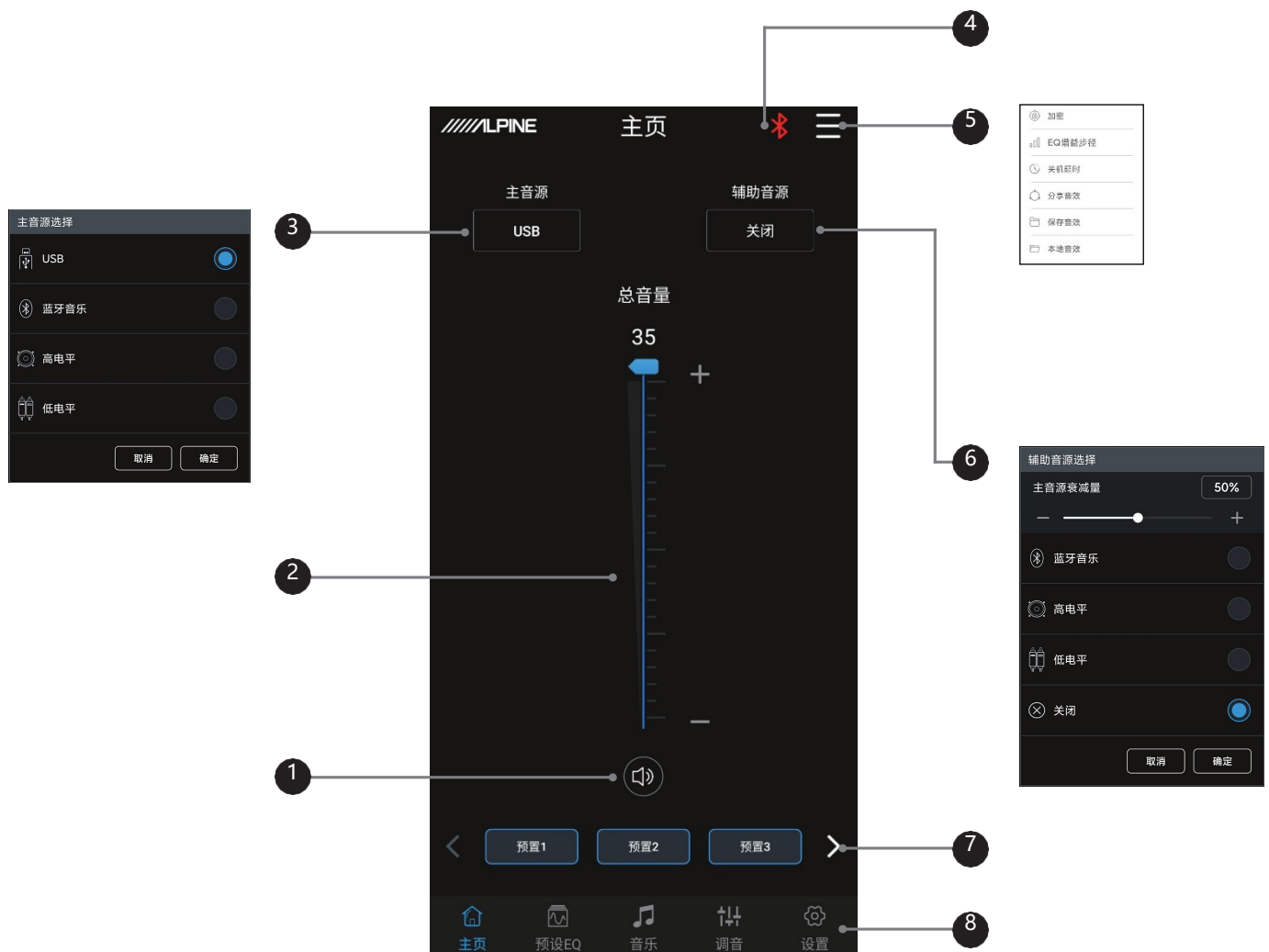

1	Mute button	Mute the master volume
2	Master volume	Pull the fader up and down to adjust the master volume.
3	Master audio source	Select the master audio source (USB, Bluetooth, High level and AUX).
4	Connection indicator	When the Bluetooth icon is red, the mobile phone Bluetooth is not connected; when it is green, the mobile phone Bluetooth is connected.
5	Menu bar	You can select Data encryption, EQ gain step size, Switch-off delay, Share sound effect, Save sound effect, and Local sound effect.
6	Auxiliary audio source	Select the auxiliary audio source (Bluetooth music, High level, AUX and OFF), and adjust the master source attenuation. The higher the attenuation of the master audio source, the lower the master volume. The attenuation range: 0%~100%.
7	Pre-set sound effect	Save and call at most 6 preset sound effect settings. Slide left and right to select different preset sound effect data.
8	Interface selection	There are 5 different functional interfaces, Homepage, Preset EQ, Music, Tuning, and Setting, and the Homepage interface is the default interface.

Description of mobile APP - Preset EQ



1	Preset EQ	You can select the preset EQ based on your personal preference. There are 10 options to choose from.
---	-----------	--

Description of mobile APP - Music



1	Previous track button	Switch to and play the previous track.
2	Play button	Switch between Pause and Play.
3	Track information display	Display information about the track being played.
4	Track album	Display the album of the track being played.
5	Audio source display	Display the master audio source and auxiliary audio source selected.
6	Play mode button	Switch play modes in cycle.
7	Play progress display	Display the play time and progress.
8	Next track button	Switch to and play the next track.

Description of mobile APP - Delay

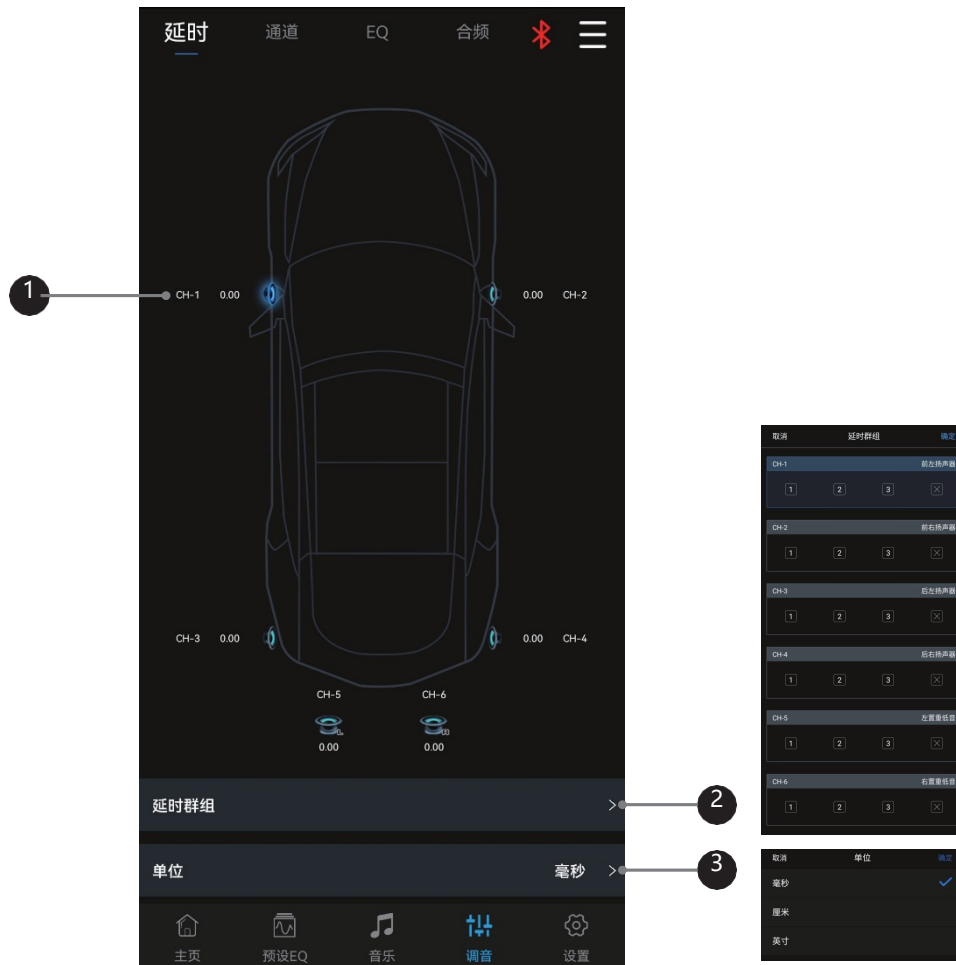

1	Speaker	Select the corresponding speaker, push the fader left and right on the pop-up window to adjust the delay, or click "+" and "-" to adjust the delay.
2	Delay group	There are 3 delay groups to choose from for each channel.
3	Unit of delay	Units of delay to choose from include ms, cm, and inch.

Description of mobile APP - Channel



1	Debugging	The debugging modes to choose from include “Copy channel EQ / volume from left to right” or “Copy channel EQ / volume from right to left”.
2	Slope	Select the divider slope (-6dB/Oct, -12dB/Oct, -18dB/Oct -24dB/Oct -30dB/Oct, -36dB/Oct, -42dB/Oct, -48dB/Oct or OFF).
3	Output channel	Slide left and right to select the output channel to set. There are 6 channels to choose from.
4	Divider	Turn on or off High-pass/Low-pass.
5	Divider frequency	Select the divider frequency (between 20Hz and 20kHz).
6	Channel volume	Push the fader left and right to adjust the channel volume, or click "+" and "-" to adjust the channel volume.
7	Channel phase	Select the channel phase (normal phase or reverse phase).

Description of mobile APP - EQ

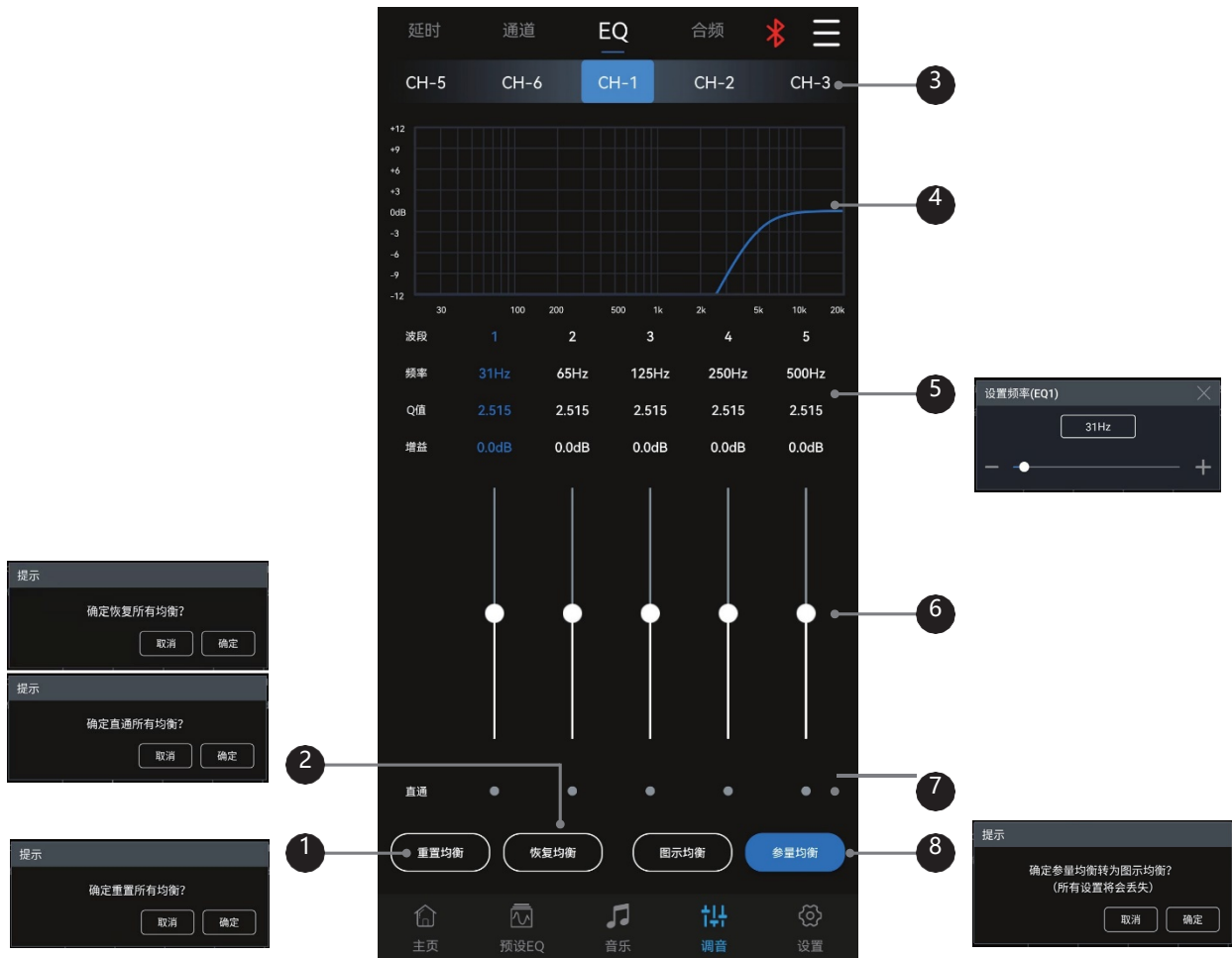

1	Reset EQ	Reset EQ setting.
2	Restore EQ, Direct EQ	Switch the tuned EQ data to direct state, click it again to restore the EQ data before Direct EQ setting.
3	Output channel	Slide left and right to select the output channel for EQ adjustment. There are 6 channels to choose from.
4	EQ display	15 sections of EQ to display the EQ adjustment curve.
5	Frequency, Q value	In the pop-up window, you can adjust the frequency and Q value of the output channel.
6	Gain	Pull the fader up and down to adjust the gain. The adjustable range is: -12.0dB~+12.0dB.
7	Waveband ON/OFF	Switch the tuned EQ data of the current waveband to the direct state, and click it again to restore the EQ data before the Direct EQ setting.
8	Parametric EQ, Graphic EQ	Switch between Parametric EQ mode and Graphic EQ mode. Mode switch would lead to loss of all settings. Frequency, Q value and gain are all adjustable in Parametric EQ mode, while gain is adjustable and frequency and Q value are fixed in Graphic EQ mode.

Description of mobile APP - Sound Mixing

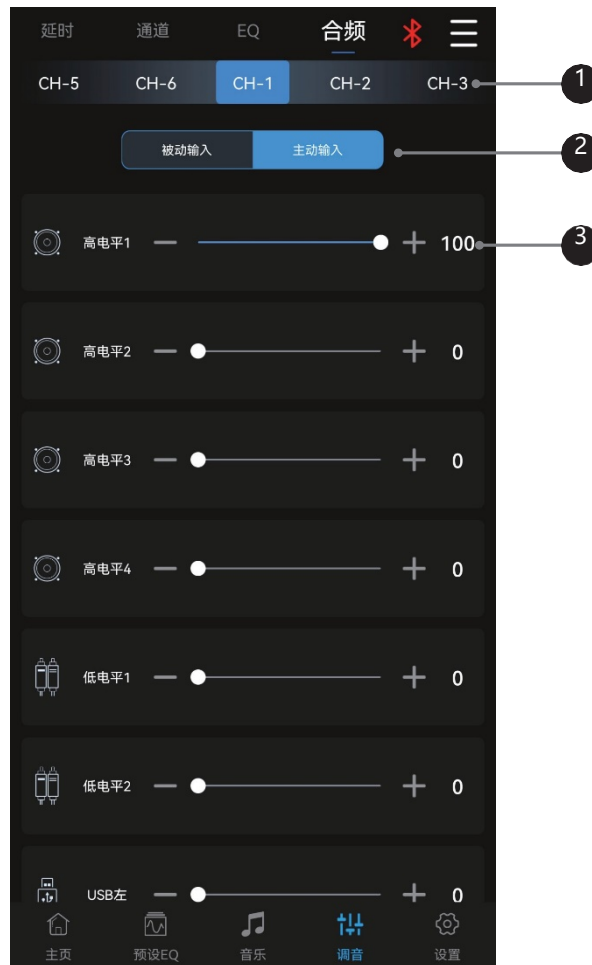

1	Output channel	Slide left and right to select the output channel for EQ adjustment. There are 6 channels to choose from.
2	Active or passive output	Keep the default setting as "Passive output". Warning: if changed, you will lose the sound mixer setting of this channel.
3	Input channel	Push the fader left and right or press "+" and "-" to adjust the volume of each audio source in the channel to achieve the purpose of sound mixing and frequency mixing.

Description of mobile APP - Setting



1	About	Check information such as device version.
2	Sound setting storage	It can call or save dealer settings and custom settings.
3	Input source volume	Adjust the volume of audio sources including USB, Bluetooth music, High level and AUX. The adjustable range is: -60dB~0dB (initial value: 0dB)
4	Audio setting	Select Treble or Bass and adjust the level; the adjustable range is: -7 ~ +7 (initial value: 0). When the subwoofer is turned on, you can adjust the phase and output level of the subwoofer.
5	Parametric Equalizer	There are 10 sections of input EQ to choose from. Click the corresponding waveband to adjust the parameters frequency, Q value and gain.
6	Built-in power amplifier	When using the pre-output of this device to drive the external amplifier, turn off the built-in amplifier; when using the built-in amplifier to drive the speaker, turn on the built-in amplifier.
7	Sound effect clear setting	When this setting is enabled, the settings on sound effects such as preset equalizer will become invalid. Disable this setting and the previous sound effect settings will be restored.

Interface of PC software

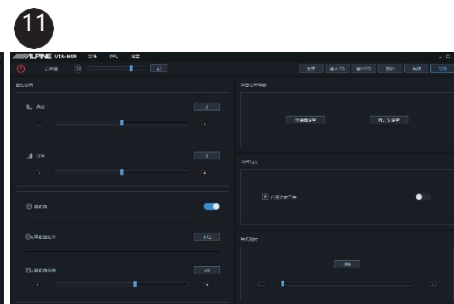
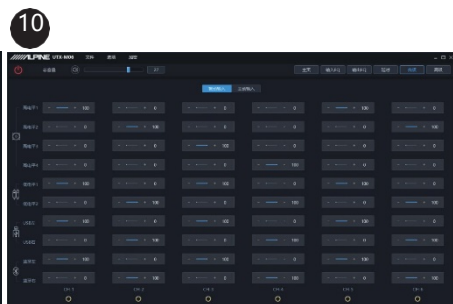
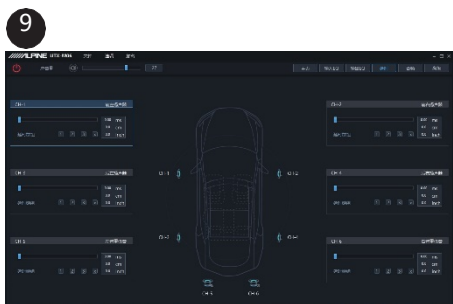
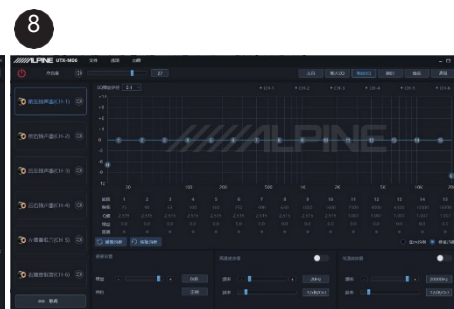
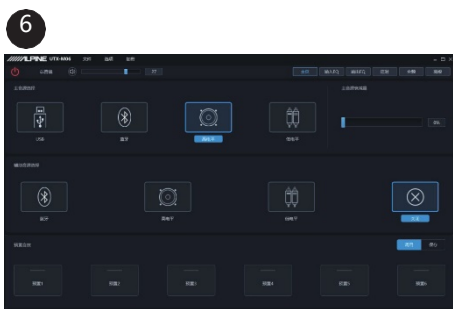
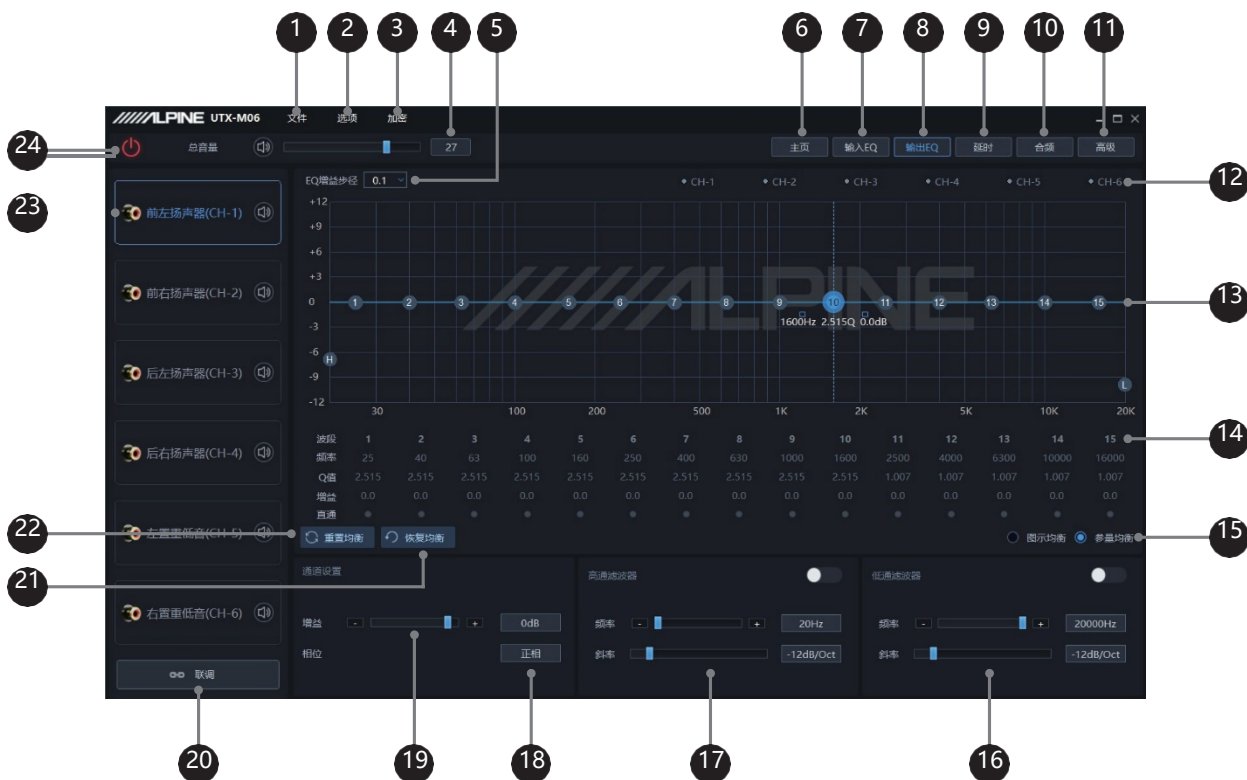

Interface of PC software

1	File	Load or save scene files on PC, load or save all scene files.
2	Options	Firmware update, restore factory settings, switch between English and Chinese, check the version number.
3	Encryption	Enter a 6-digit password to encrypt the tuned sound effect data.
4	Master volume	Push the fader left and right to adjust the master volume. Click the speaker button to mute.
5	EQ gain step size	Step size can be chosen from the range: 0.1dB~0.5dB~1.0dB.
6	Homepage	Selection of master audio source (USB, Bluetooth, High level and Low level), selection of auxiliary audio source (Bluetooth, High level, Low level and OFF), attenuation adjustment of the master audio source, call or storage of preset sound effect.
7	Input EQ	Enter the Input EQ interface. There are 10 sections of input EQ. Select input EQ.
8	Output EQ	Enter the Output EQ interface. There are 15 sections of output EQ. Professional tuning interface.
9	Delay	Enter the Delay interface, set the delay value, unit of delay and delay group.
10	Frequency combination	Enter the Frequency combination interface, Sound mixing and Frequency mixing setting.
11	Advanced	Audio setting, Sound setting storage, Built-in power amplifier ON/OFF and Switch-off delay setting.
12	Output channel display	Display the output channel curve.
13	EQ curve	Display the current EQ curve status, set the frequency, Q value and gain.
14	Frequency, Q value, Gain	Adjust the frequency, Q value and gain of the output channel.
15	Parametric EQ, Graphic EQ	Switch between Parametric EQ mode and Graphic EQ mode. Mode switch would lead to loss of all settings. Frequency, Q value and gain are all adjustable in Parametric EQ mode, while gain is adjustable and frequency and Q value are fixed in Graphic EQ mode.
16	Low-pass filter	Turn on or off the low-pass filter to cut off high frequency. Select the divider frequency (between 20Hz and 20kHz). Select the divider slope (-6dB/Oct, -12dB/Oct, -18dB/Oct -24dB/Oct -30dB/Oct, -36dB/Oct, -42dB/Oct, -48dB/Oct or OFF).
17	High-pass filter	Turn on or off the high-pass filter to cut off low frequency. Select the divider frequency (between 20Hz and 20kHz). Select the divider slope (-6dB/Oct, -12dB/Oct, -18dB/Oct -24dB/Oct -30dB/Oct, -36dB/Oct, -42dB/Oct, -48dB/Oct or OFF).
18	Channel phase	Select the channel phase (normal phase or reverse phase).
19	Channel gain	Push the fader left and right to adjust the channel gain, that it, to adjust the volume of the output channel; the adjustable range is: -60dB~+6dB.
20	Debugging	The debugging modes to choose from include “Copy channel EQ / volume from left to right” or “Copy channel EQ / volume from right to left”.
21	Direct EQ, Restore EQ	Switch the tuned EQ data to direct state, click it again to restore the EQ data before Direct EQ setting.
22	Reset EQ	Reset EQ setting.
23	Output channel	There are 6 output channels to choose from. Configure the type of output channel. Click the speaker button to mute.
24	Connection indicator	Connect the PC and the host machine with a USB cable. Open the software to connect the device. Click it again to turn off the connection.

Specification parameters

Interface	USB 2.0/MICRO SD
Capacity	Supports a maximum of 128G each
Maximum power consumption	1.5A
File system	FAT16/32
Maximum number of playable tracks	5000 tracks
PCM encoding	192kHz, 16~24bit
MP3 decoding	MPEG Audio Layer-3
WMA decoding	Windows Media™ audio
WAV decoding	waveform audio file
FLAC decoding	Free Lossless Audio Codec
APE decoding	Monkey's Audio
Audio format supported by Bluetooth	AAC/SBC
System sampling rate	96kHz/24bit
Power supply requirements	14.4V DC (allowable 9~16V)
Controller screen	2.4 inches color TFT display (480×320)
Net weight	0.77kg
Dimensions of host machine	178mm×143.6mm×50mm
Dimensions of controller	111mm×50mm×17.5mm

Functional parameters

Input signals	4 channels of high level, 2 channels of RCA audio and high resolution blue tooth
Output signals	4 channels of high level, 6 channels of RCA audio
Signal gain of output channel	Range: mute, -60dB~+6dB
Output signal equalizer	Type: parametric EQ, graphic EQ Frequency: 20Hz~20kHz, resolution: 1Hz Q value (slope or gradient): 0.404~28.852 Gain: -12.0dB~+12.0dB, resolution can be selected from 0.1dB~0.5dB~1.0dB
Output signal frequency divider	Each output channel is equipped with an independent multi-order high-pass filter Filter type: Butterworth by default, resolution: 1Hz Filter cross-over frequency: 20Hz~20kHz Filter slope (gradient): -6dB/Oct ~ -48dB/Oct
Output phase	Normal phase or reverse phase
Output delay	0.00~10.42ms, 0.0~354.3cm, 0.0~139.6inch
Pre-set sound effects	6 sets of pre-set sound effect data can be saved in the device

Functional parameters

Dynamic range	≥110dB
Signal to noise ratio	AUX≥100dB
Background noise	High level≤-75dBu; AUX≤-95dBu
Channel resolution	≥80dB
THD	≤0.01%
Input voltage	High level: 26Vpp; AUX: 8Vpp
Output voltage	12Vpp
Rated power	4CH×25W (4Ω, 14.4V, 1kHz, 10%THD)
Maximum power	4CH×50W (4Ω, 14.4V, 1kHz, 10%THD)
Input / output sensitivity	AUX≥1:1.5
Frequency response	20Hz~40kHz
Input impedance	High level: 51Ω; AUX: 20kΩ
Output impedance	51Ω
Quiescent current	≤3mA (in off state)
Stand-by power consumption	≤0.1W
REM startup input	ACC or High level (FL-/FL+)
REM startup output	12V (0.2A)
Uptime	18s
Operating ambient temperature	-20~60°C
Storage temperature	-40~85°C

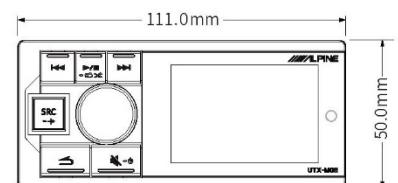
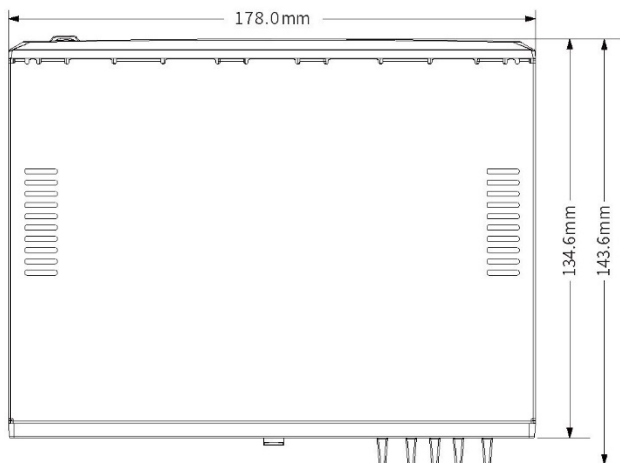
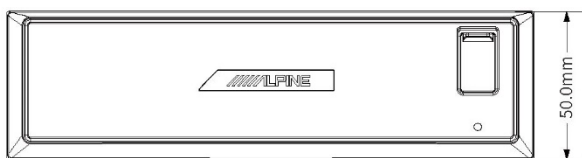

Operating instructions for installation

Before installing or connecting this device, please read the following instructions and refer to “Operating Instructions” to ensure correct use.

Please make correct connections	Incorrect connection may result in fire or damage to this product. Professional expertise and experience are required to wire and install the device. Please contact the dealer from whom you bought the product to install it for safety.
Please only use the device on 12 V negative grounded vehicles	Otherwise, it may lead to an accident like a fire (If you are not sure, please consult the agent for confirmation).
Please make sure that the negative terminal of the battery is removed before wiring	Before wiring, please remove the cable connected to the negative terminal of the battery. Otherwise, it may result in electric shock or injury due to a short circuit.
Please do not cut the cable	Never strip the cable insulation to supply power to other devices. Otherwise, it may result in fire or electric shock by exceeding the rated load of the cable.
Please be careful not to damage the tubing or wire when drilling	When drilling an installation hole on the chassis, please be especially careful not to touch, damage, or obstruct the tubing, oil line, fuel tank or wire. Otherwise, it may result in fire.
Please do not use a bolt or nut on the braking or steering system for grounding	Bolts or nuts used on the braking or steering system (or any other safety related system) or the fuel tank should never be used for installation or connection of the grounding wire. Otherwise, it will cause the failure of vehicle control or fire and so on.
Please keep small items like batteries out of the reach of children	If ingested, it may result in severe injury. Once ingested, please seek medical attention immediately.
Please watch for the installation site	Please do not install the device in a place that will hinder the driving of the vehicle; otherwise, it may obstruct the view to the front or hinder the driving and cause a serious accident; Please do not install the device in a place under direct sunlight; otherwise, exposure to direct sunshine at high temperatures may damage the screen; Please do not install the device in an extremely humid or dusty place, as moisture or dust incursion into the inside may cause the device's failure.
Please do not allow the cable to twist around surrounding objects	Please arrange the cables and wire as per the instructions to avoid hindering driving. Any cable or wire hindering or hanging on the steering wheel, gear lever, or brake pedal is very dangerous.
Please use the specified accessories and perform installation in a safe manner	It needs professional expertise and experience to wire and install the device. Please contact the dealer from whom you bought the product to install it for safety.
Please arrange the cables and wire properly to avoid compression or pinch by a sharp metal edge	The installation path of cables and wires should be far from movable components (such as seat slide) or sharp metal edges to avoid cable and wire damage. If a wire needs to pass through a hole in a metal part, please wrap it with a rubber washer to protect the wire insulation from being cut by the edge of the hole.

Precautions for installation

- Before installing UTX-M06, please make sure to disconnect the cable from the battery's negative terminal (-). This can reduce the chance of damage to this device in the case of a short circuit.
- Please make sure to connect the color coded wires as shown in the diagram. Incorrect connection may cause the failure of this device or damage to the electrical system of the vehicle.
- When connected to the vehicle's electrical system, please watch for the factory installed components (such as on-vehicle computer). Please do not use these wires to supply power for this device.
- When connecting UTX-M06 to the fuse box, please make sure that the amperage of the circuit fuse used for UTX-M06 is appropriate. If not, it may result in damage to this device and/or the vehicle. For any questions, please consult your Alpine dealer.
- UTX-M06 uses a recessed RCA socket for connection with other devices with RCA connector (such as amplifier). You may need an adaptor for connection with other devices. If you need an adaptor, please contact your Alpine authorized dealer.
- Please make sure to connect the speaker (-) wire to the speaker (-) terminal. Be sure not to connect the wires of the left and right speakers to each other or the vehicle body.

Important notes:

Please fill in the serial number of this device in the brackets and save it permanently. The serial number is on the label at the top of the device.

Serial number: []
Installation date: []
Installation technician: []
Place of purchase: []

When a problem occurs

If you encounter any problem, please turn off the power and turn it on again. If the device still cannot work, please check the items in the table below. If the device fails, this manual will help you solve the problem. Otherwise, please confirm that your system is connected correctly or consult your Alpine authorized dealer.

1	Common problems	<p>Function cannot be used or displayed.</p> <ul style="list-style-type: none"> · The ignition switch of the vehicle is off. <ul style="list-style-type: none"> - If connected as per the instructions, this device will not run when the vehicle's ignition switch is off. · Power cord (red) and battery wire (yellow) are connected incorrectly. <ul style="list-style-type: none"> - Check the wiring of the power cord and battery wire. · The fuse blows out. <ul style="list-style-type: none"> - Check the fuse of the device. If needed, replace it with a new fuse with appropriate specifications. · Failure occurs to the microcomputer inside due to interfering noise and so on. <ul style="list-style-type: none"> - Press RESET with a ballpoint or other pointed object.
2	Format problems	<p>Failure to play MP3/WMA/WAV/FLAC/APE.</p> <ul style="list-style-type: none"> · Write error occurs. Incompatible with MP3/WMA/WAV/FLAC/APE formats <ul style="list-style-type: none"> - Ensure writing of MP3/WMA/WAV/FLAC/APE in a supported format.
3	Audio problems	<p>Sound is not output from the speaker.</p> <ul style="list-style-type: none"> · The built-in amplifier does not output a signal. <ul style="list-style-type: none"> - The switch of the built-in power amplifier has been turned to “On”.
4	Instructions for USB storage	<p>USB transmission error: Communication failure or startup failure etc.</p> <ul style="list-style-type: none"> - The problem can be solved by turning off/on ACC. <p>Device not supported: A USB device not supported by this device is connected.</p> <ul style="list-style-type: none"> - Connect USB devices supported by this device, such as USB flash disk or MICRO SD. <p>The device has no response: The USB device has no response.</p> <ul style="list-style-type: none"> - Please reinsert the USB device. <p>Please insert a USB device: No USB storage is connected.</p> <ul style="list-style-type: none"> - Make sure that the USB storage is correctly connected and the cable is not overbent. <p>No tracks: There are no tracks (files) in the USB storage.</p> <ul style="list-style-type: none"> - Connect a USB storage device with tracks (files) in it. <p>Protected file: A WMA file with copy protection is played.</p> <ul style="list-style-type: none"> - The device can only play files without copy protection. <p>Device not connected: No Bluetooth device is connected.</p> <ul style="list-style-type: none"> - Connect a Bluetooth device. <p>No tracks: There are no tracks on the Bluetooth device.</p> <ul style="list-style-type: none"> - Please download tracks to the Bluetooth device.

Radio law on Bluetooth

Regulatory requirements of radio law on Bluetooth:

China	<p>1. Technical indicators of this product:</p> <ul style="list-style-type: none"> · Use frequency: 2.4-2.4835 GHz · Equivalent isotropically radiated power (EIRP): Antenna gain < 10dBi: $\leq 100\text{mW}$ or $\leq 20\text{dBm}$ · Maximum power spectral density: Antenna gain < 10dBi: $\leq 20\text{dBm/MHz}$ (EIRP) · Carrier frequency tolerance: 20 ppm · Out of band emission power (out of the 2.4-2.4835 GHz frequency band): $\leq -80\text{dBm/Hz}$ (EIRP) · Spurious emission (radiation) power (out of corresponding carrier ± 2.5 times channel bandwidth): $\leq -36\text{dBm}/100\text{kHz}$ (30-1000MHz) $\leq -33\text{dBm}/100\text{kHz}$ (2.4-2.4835GHz) $\leq -40\text{dBm}/1\text{MHz}$ (3.4-3.53GHz) $\leq -40\text{dBm}/1\text{MHz}$ (5.725-5.85GHz) $\leq -30\text{dBm}/1\text{MHz}$ (Other 1-12.75 GHz) <p>2. No emission frequency change or emission power increase (including the addition of RF power amplifier) is allowed without permission. No use of an external antenna or switch to another emission antenna without permission is allowed;</p> <p>3. No harmful interference to various lawful radio communication services shall be produced during the use; once interference is found, the use shall be stopped immediately and shall not be resumed before measures are taken and the interference is eliminated;</p> <p>4. For the use of micro power radio devices, the interference of various radio services or the radiated interference of devices for industrial, scientific, and medical use must be tolerated.</p> <p>5. Use near an aircraft or airport is forbidden.</p>
-------	---

Hazardous substances

Name and content of hazardous substances or elements in the product

Component	Hazardous substance or element					
	Lead (Pb)	Mercury (Hg)	Cadmium (Cd)	Hexavalent (Cr(VI))	Polybrominated biphenyls (PBB)	Polybrominated diphenyl ethers (PBDE)
Circuit board assembly	×	O	O	O	O	O
Housing assembly	O	O	O	O	O	O
Display assembly	×	O	O	O	O	O
Accessory	×	O	O	O	O	O

This table is prepared in accordance with the requirements of SJ/T 11364.

O: indicates that the content of this hazardous substance in this component is below the limit specified by GB/T 26572.

×: indicates that the content of this hazardous substance in at least a homogeneous material of this component exceeds the limit specified by GB/T 26572.

For components marked with “×”, the content exceeding the limit is because there is currently no mature alternative technology in the industry at present.

Information on maintenance stations

- For a consultation about maintenance, please refer to "Information of maintenance stations" below.
- The name, telephone number, and address of maintenance stations may be changed.

Serial number	Maintenance station	Address	Postal code	Tel
1	Shanghai maintenance station	1st floor, No. 12 Lane 158, Tongpu Road, Putuo District, Shanghai	200062	021-626056 45
2	Guangzhou maintenance station	No. 3 Shanhe Street, Jingxi Road, Baiyun District, Guangzhou	510510	186-6505-9713
3	Zhengzhou maintenance station	3rd floor, No. 7 Yard, Jingbei First Road, Zhengzhou Economic and Technological Development Zone	450016	0371-662223 88
4	Kunming maintenance station	Store No. 407-408, Taiyang Xincheng, Longquan Road, Kunming	650031	0871-651162 01
5	Nanjing maintenance station	Room 108, Center Building 1, Xingdu Qingxuan, Jingwu Road, Qixia District, Nanjing	210003	025-866 03 68
6	Hangzhou maintenance station	No. 80-6 Wenjiao Road, Fuyang District, Hangzhou	311400	
7	Xiamen maintenance station	Store No. VI, VII & VIII, No. 248 Houdaixi Road, Xiamen	361004	0592-5170118
8	Urumchi maintenance station	No. 308 Qingnian Road, Urumchi	830002	0991-8871299
9	Nanchang maintenance station	Ground floor, Fengyuan Jiahui Chaoyangju, No. 98 Xinzhou Road, Nanchang	330029	0791-865 66758
10	Chengdu maintenance station	No. 1333 Zone B1, Dongli International Square, Simaqiao, Chenghua District, Chengdu	610051	028-843 97796

For the latest and most detailed information of maintenance stations, please visit www.alpine.com.cn.